

EN

RESIDENTIAL ENERGY STORAGE BATTERY

TURBO H4

Series

User Manual

V00



- TB-H4-5
- TB-H4-10
- TB-H4-15
- TB-H4-20
- TB-H4-25
- TB-H4-30

RENAC

Content

1.	About this manual	4
1.1	Applicability	4
1.2	Target group	4
1.3	Symbols used	4
1.4	Designation in the document	4
2.	Safety	5
2.1	General safety	5
2.2	Important safety instructions	5
2.3	Explanation of symbols	6
3.	Introduction.....	7
3.1	Product overview.....	7
3.2	Product dimensions.....	9
3.3	Technical data.....	11
4.	Installation	12
4.1	Unpacking.....	12
4.2	Preparation for installation.....	13
4.2.1	Installation tools	13
4.2.2	Protective tools.....	14
4.3	Installation environment.....	14
4.4	Space requirement	15
4.5	Installation steps.....	15
5.	Electrical wiring connection.....	19
5.1	Port.....	20
5.2	Grounding cable preparation	20
5.3	Battery power cable connection	21
5.4	Communication cable connection.....	23
5.5	Close the cover	24
6.	LED indicator status	24
7.	Commissioning.....	25

7.1	Check before operation	25
7.2.	Power on	25
7.3.	Power off.....	25
8.	Troubleshooting and maintenance	26
8.1	Troubleshooting.....	26
8.2	Maintenance.....	27
9.	Decommissioning.....	27
9.1	Dismantling the battery	27
9.2	Packaging	28
9.3	Storage	28
9.4	Disposal	28

Notice

This manual contains important safety instructions, installation, electrical connections, commissioning, maintenance, and troubleshooting of the equipment.

Save the manual

This manual must be stored carefully and be available at all times.

Copyright Declaration

All rights to the content of this manual are owned by RENAC Power Technology Co., Ltd. (hereinafter called as 'RENAC Power'). Any corporation or individual should not plagiarize, partially or fully copy it, and reproduce or distribute it in any form or means without prior written permission from RENAC Power.

RENAC Power reserves the right of final interpretation. This manual may be updated according to user's or customer's feedback. The information in this manual is subject to change without notice. Every effort has been made to ensure the accuracy of the contents of this manual, but nothing mentioned herein expresses or implies any other information. Please check our website at <http://www.renacpower.com> for latest version.

1. About this manual

1.1 Applicability

Please read the product manual carefully before installation, operation or maintenance. This manual contains important safety instructions and installation instructions that must be followed during installation and maintenance of the equipment.





1.2 Target group

The instructions in this document may only be performed by qualified persons who must have the following skills:

- Knowledge of how batteries work and are operated.
- Knowledge of how an inverter works and is operated.
- Knowledge of and adherence to the locally applicable connection requirements, standards, and directives.
- Knowledge of and adherence to this document and the associated system documentation, including all safety instructions.
- Training in dealing with the hazards associated with the installation and operation of electrical equipment and batteries.
- Training in the installation and commissioning of electrical equipment.
- Failure to do so will make any manufacturer's warranty, guarantee or liability null, and void unless you can prove that the damage was not due to non-compliance.

1.3 Symbols used

The following types of safety instructions and general information appear in this document as described below:

	<p>'Danger' indicates a hazard with a high level of risk that, if not avoided, will result in death or serious injury.</p>
	<p>'Warning' indicates a hazard with a medium level of risk that, if not avoided, will result in death or serious injury.</p>
	<p>'Caution' indicates a hazard with a low level of risk that, if not avoided, could result in minor or moderate injury.</p>
	<p>'Notice' indicates a situation that, if not avoided, could result in equipment or property damage or provides tips that are valuable for the optimal operation of your product.</p>

1.4 Designation in the document

The following types of safety instructions and general information appear in this document as described below:

AFE	Analog Front End
BAT	Battery
BMC	Battery Master Controller
BMS	Battery Master System
CMU	Cell monitor Unit
DOD	Depth of Discharge
LED	Light Emitting Diode
PV	Photovoltaic
RBS	Rechargeable Li-ion Battery Stack
SOC	State of Charge

2. Safety

2.1 General safety

The Turbo H4 Series battery is for residential and works with a photovoltaic system. It is a high voltage Li-ion battery storage system, with the control module on itself. Read safety instructions carefully prior to any work and observe them at all times when working on or with Turbo H4 Series battery. Incorrect operation or work may cause:

- ◆ Injury or death to the operator or a third party;
- ◆ Damage to the inverter or other properties.

2.2 Important safety instructions



- Direct contact with live parts or DC cables is prohibited, and the voltage at the point of contact should be measured to confirm that there is no risk of electric shock before contacting any conductor surface or terminal.
- DC cables connected to the inverter may be electrically charged. Touching live DC cables can result in death by electrocution or serious injury.
- Before working on the equipment, disconnect the battery system and the inverter from the voltage source and make sure that it cannot be reconnected.
- Do not touch non-insulated parts or cables.
- Before installing the cable, make sure that the cable label is correctly marked and that the cable terminals are properly insulated.
- Never remove terminal blocks with connected DC leads from their slots under load.
- Wear appropriate personal protective equipment for all work on the battery system.
- Observe all safety information for the inverter.



◆ Battery Module Leakage:

Avoid contact with the leaking liquid or gas if the battery module leaks electrolyte. The electrolyte is corrosive, and contact with it may cause skin irritation and chemical burns. If you come into contact with the leaking material, take the following steps:

- Inhalation: Evacuate the contaminated area and seek immediate medical attention.
- Eye contact: Flush eyes with running water for 15 minutes and seek immediate medical attention.
- Skin contact: Wash the affected area thoroughly with soap and water and seek immediate medical attention.
- Ingestion: Induce vomiting and seek medical attention immediately.

◆ Firefighting Measures:

Suppose the gas extinguishing system fails to extinguish the fire. In that case, emergency responders should activate the water extinguishing system after confirming that the power to the battery system has been disconnected, then quickly evacuate to a safe area and wait for firefighters to extinguish the fire. After firefighters arrived to extinguish the fire, keep spraying water for 12 hours. After the firefighters confirm on-site that the equipment temperature has dropped to room temperature $\pm 10^{\circ}\text{C}$, observe the equipment for 24 hours to ensure that the temperature does not rise and that there is no smoke.

Battery fires may release flammable and toxic gases, so keep them away from the battery.



- ◆ Protect the battery module and its components from damage during transport and handling.
 - Do not shock, pull, drag, or step on the battery module.
 - Do not insert extraneous objects into any part of the battery module.
 - Do not throw the battery module into a fire.
 - Do not immerse the battery module in water or seawater.
 - Do not be exposed to strong oxidizing agents.
 - Do not short-circuit the battery module.
 - The battery module must not be stored in a high-temperature environment (above 50°C).
 - The battery module cannot be stored in direct sunlight.
 - The battery module must not be stored in a high-humidity environment.
 - Do not use the battery module if it is defective, if it is cracked, broken, or otherwise damaged, or if it does not operate.
 - Do not attempt to open, disassemble, repair, tamper with, or modify the battery module. The user cannot repair the battery module.
 - The battery module may cause injury if it is improperly lifted or dropped during transport or installation.
 - Wear appropriate personal protective equipment for all work on the battery system.
 - If the battery is not installed within one month of receipt, the battery must be charged to over 50% SOC for maintenance.











All electrical installations must comply with national and local standards and regulations.
 To prevent personal injury, make sure the power battery system is grounded.
 Do not remove the labels on the battery system.
 If the battery is visibly damaged or malfunctions in a way that cannot be resolved, contact RENAC after-sales service within 48 hours. Otherwise, the battery may be permanently damaged.
 The battery does not contain repair parts; if repairs are required, contact RENAC after-sales service or a local authorized agency.

2.3 Explanation of symbols

This section gives an explanation of all the symbols shown on the type label.
 Symbols on the Type Label:

Symbol	Explanation
	TÜV mark
	CE mark
	Cyclic regeneration.
	ABC fire extinguishers.

Symbol	Explanation
	Do not disconnect or disassemble by untrained personnel.
	Do not short circuit.
	Do not expose the battery to open flame, heat or sparks, as there is a risk of fire or explosion.
	Keep the battery stacks away from children.
	Observe the documents Observe all documents supplied with the system.
	Warning! Metal parts of the batteries are always under voltage. Do not short-circuit the batteries! In case of a short-circuit may flow very high currents and cause burns. By Touching conductive parts can cause cardiac arrhythmia and shock.
	The battery contains corrosive electrolytes. Please avoid contact with the leaked substance.
	WEEE designation Do not dispose of the system together with the household waste but in accordance with the disposal regulations for electronic waste applicable at the installation site.

3. Introduction

3.1 Product overview

The Turbo H4 is a stacked high-voltage battery consisting of a high-voltage control box (BMC) and a battery pack for applications requiring high power output, limited mounting space, limited load bearing, and long cycle life.

Model name: **TB-H4-5**

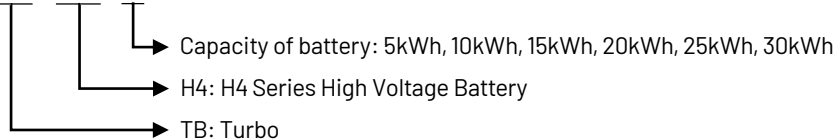

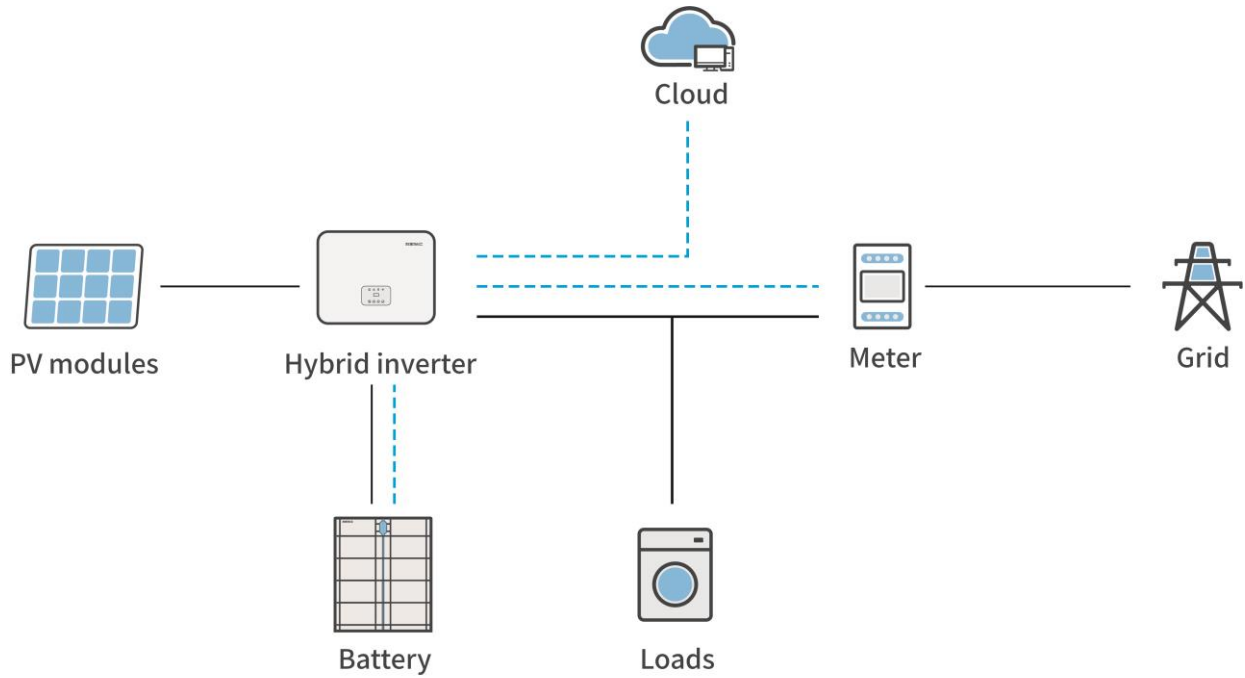

Figure 3-1 Battery application

Turbo H4 series battery is matched to the hybrid inverters of RENAC in the table below:

Model	TB-H4-5	TB-H4-10	TB-H4-15	TB-H4-20	TB-H4-25	TB-H4-30
System Demo						
Number of Modules	1BMC+1RBS	1BMC+2RBS	1BMC+3RBS	1BMC+4RBS	1BMC+5RBS	1BMC+6RBS
Matching N1-HV-3-6K	✓	✓	✓	✓		
Matching N3-HV-5-10K		✓	✓	✓	✓	✓
Matching N3 Plus 15-30K				✓	✓	✓

Please refer to the Hybrid inverter manual or consult the pre-sales for the meter-matching inverter solution.

3.2 Product dimensions

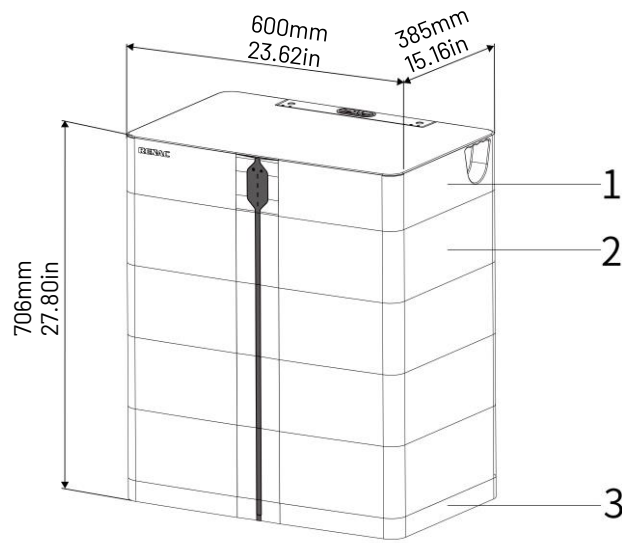

Figure 3-2 Dimensions of Turbo H4 (Take TB-H4-20 for example)

No.	Name
1	Battery Master Controller (BMC700)
2	Rechargeable Li-ion Battery Stack (B9652-S)
3	Base

BMC view:

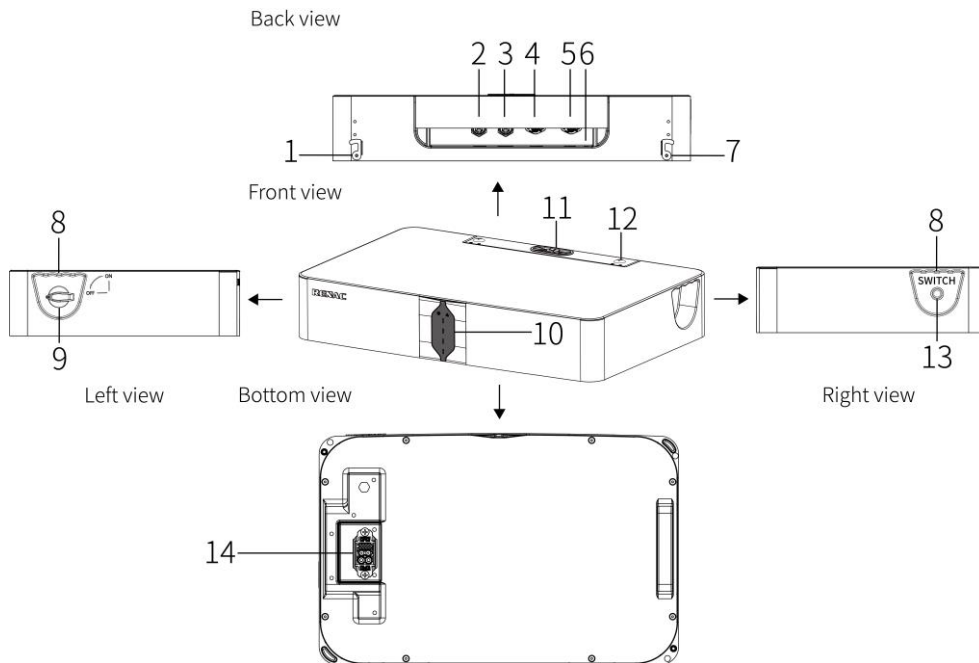

Figure 3-3 View of BMC700

No.	Name
1	Lockout hasp A: Fix between BMC and RBS.
2	CAN: Connect the "CAN" port of BMC700 to the "BMS-CAN/485" port of inverter.

No.	Name
3	RS485: Debug port.
4	BAT+: Connect the "BAT+" port of BMC700 to the "BAT+" port of inverter.
5	BAT-: Connect the "BAT-" port of BMC700 to the "BAT-" port of inverter.
6	Grounding terminal: Connect to the earth.
7	Lockout hasp B: Fix between BMC and RBS.
8	Handle: For manual handling of BMC.
9	DC switch: A switch for the battery's input and output.
10	LED: LED state can be found in chapter 6.
11	Cable protection ring: Easy to thread and protect cables.
12	M4 screws: Lock the cover.
13	Start switch: Start system.
14	Heavy Duty Connector (Male): Connect to the top of RBS.

RBS view:

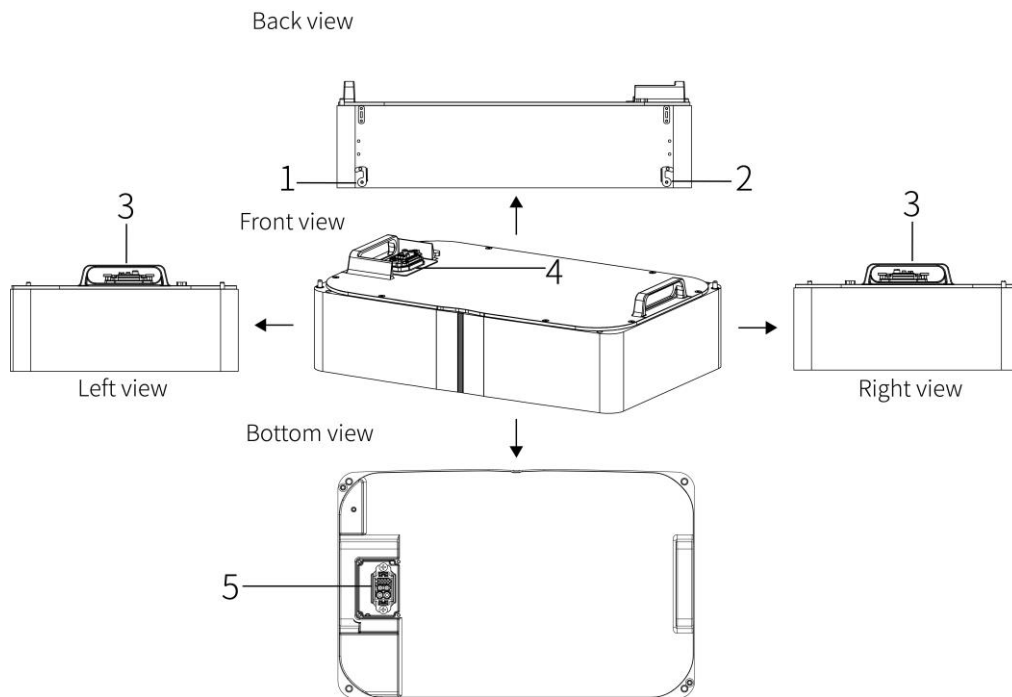

Figure 3-4 View of B9652-S

No.	Name
1	Lockout hasp A: Fix between RBS and RBS.
2	Lockout hasp B: Fix between RBS and RBS.
3	Handle: For manual handling of RBS.
4	Heavy Duty Connector (Female): Connect to the bottom of battery pack or BMC.
5	Heavy Duty Connector (Male): Connect to the top of RBS.

Base view:

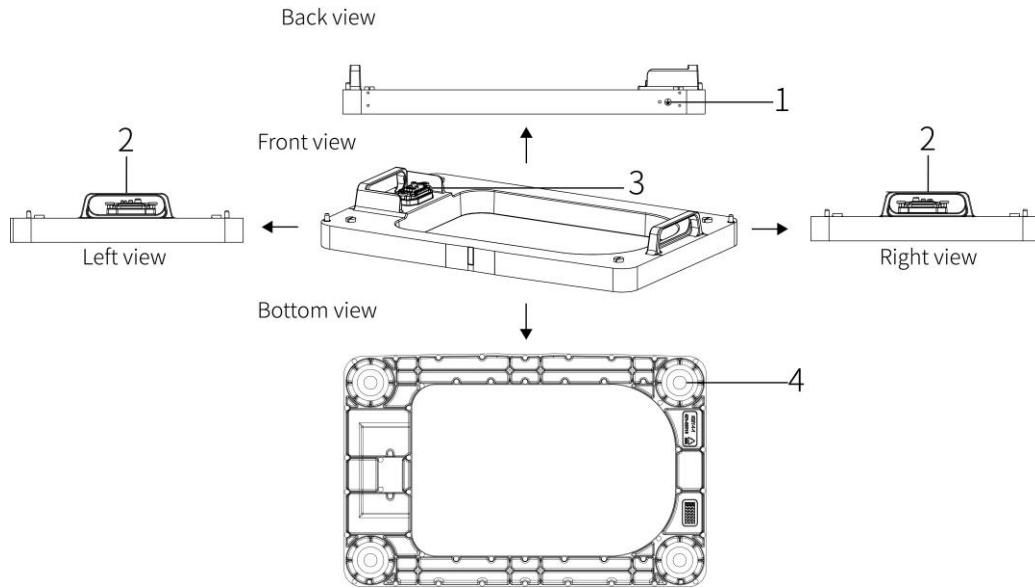

Figure 3-5 View of base

No.	Name
1	Grounding terminal: Connect to the earth (Reserve).
2	Handle: For manual handling of base.
3	Heavy Duty Connector (Female): Connect to the bottom of RBS.
4	Supporting foot: Base adjustment ($\leq 5\text{mm}$).

3.3 Technical data

Model	TB-H4-5	TB-H4-10	TB-H4-15	TB-H4-20	TB-H4-25	TB-H4-30
Electrical Parameters						
System Demo						
Number of Modules	1BMC+1RBS	1BMC+2RBS	1BMC+3RBS	1BMC+4RBS	1BMC+5RBS	1BMC+6RBS
Nominal Energy (kWh) ^[1]	5	10	15	20	25	30
Nominal Power (kW)	2.88	5.76	8.64	11.52	14.4	17.28
Nominal Voltage (V)	96	192	288	384	480	576
Voltage range (V)	81 ~ 108	162 ~ 216	243 ~ 324	324 ~ 432	405 ~ 540	486 ~ 648
Max. Continuous Charging / Discharging Current (A)	30 / 30					
Depth of Discharge	90%					
Cooling	Natural					
General Data						
Battery technology	LiFePO4					

Model	TB-H4-5	TB-H4-10	TB-H4-15	TB-H4-20	TB-H4-25	TB-H4-30
Dimensions (W*H*D) (mm)	600*289*385	600*428*385	600*567*385	600*706*385	600*845*385	600*984*385
Weight (kg)	64	110.3	156.6	202.9	249.2	295.5
Ingress Protection	IP65 (Indoor or Outdoor)					
Installation Type	Floor Stand					
Operating Temperature Range (°C) [2]	-10 ~ +55					
Relative Humidity	0 ~ 95%					
Communication	CAN / RS485					
Cycle Life	6000 @80% DOD / 25°C / 0.2C / 60% EOL					
Warranty (years) [3]	10					
Operating Altitude (m)	≤ 2000					
Certification						
Certificates	UN38.3, EN / IEC 62619, IEC 63056, EN 62477, EN 61000-6-1 / -3, Annex I of Regulation (EU) 2023/1542, Annex XVII of REACH Regulation					

[1] Nominal Energy: 100% DOD, 0.2C charge & discharge at +25°C (test conditions).

[2] Ambient temperature charging (0 ~ +53°C), discharging (-10 ~ +53°C).







[3] Conditions apply: refer to RENAC Power Battery Warranty Policy.



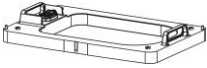

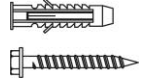
4. Installation

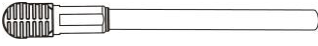
4.1 Unpacking



Before opening the package, please check whether the packing box is complete and whether there is any damage, soaked in water; if the package is incomplete or obviously damaged, please contact the supplier. If the package is complete, please open the box to check whether the contents are complete against the material list or as shown in the figure below; if there is any omission or damage, please contact the supplier.

BMC & Base packing:

No.	Shape	Model	Quantity
1		Base	1
2		BMC700	1
3		Anti-tipping plate combination	2
4		Expansion tube & Expansion screw	2
5		Cross pan head combination screws M5*10	2
6		OT terminal	2
7		Red power cable (P+, 2m)	1
8		Black power cable (P-, 2m)	1



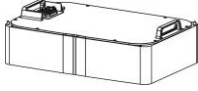



No.	Shape	Model	Quantity
9		Communication cable (2m)	1
10		Quality Certificate	1
11		User Manual	1
12		Quick Installation	1

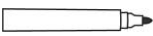

RBS packing:

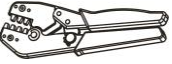
No.	Shape	Model	Quantity
1		B9652-S	1
2		Quality Certificate	1

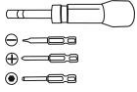
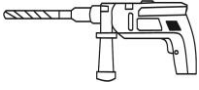



4.2 Preparation for installation

4.2.1 Installation tools

No.	Tool	Model	No.	Tool	Model
1		Spirit level	7		Marker
2		Wire stripper	8		Rubber hammer
3		Crimping tool	9		Hex key
4		Heat gun	10		Torque screwdriver
5		Hammer drill	11		Multimeter

No.	Tool	Model	No.	Tool	Model
6		φ 6mm Heat shrink tube	12		4mm ² Grounding cable

4.2.2 Protective tools

No.	Tool	Model	No.	Tool	Model
1		Dust mask	4		Insulated shoes
2		Goggles	5		Safety helmet
3		Insulated gloves			

4.3 Installation environment

Requirements for Installation Location.

- A solid support surface must be available (e.g., concrete or masonry).
- The installation location must be inaccessible to children.
- The installation location must be suitable for the weight and dimensions of the battery system.
- The installation location must not be exposed to direct solar irradiation.
- The installation location must not be close to the fire.
- The altitude of the installation location should be less than 2000m.
- The ambient temperature should be between -10°C and +53°C.
- The ambient humidity should be between 0 ~ 95%.

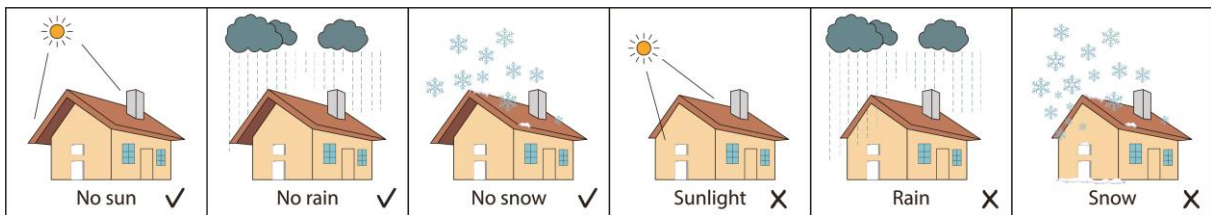

Figure 4-1 Installation environment

4.4 Space requirement

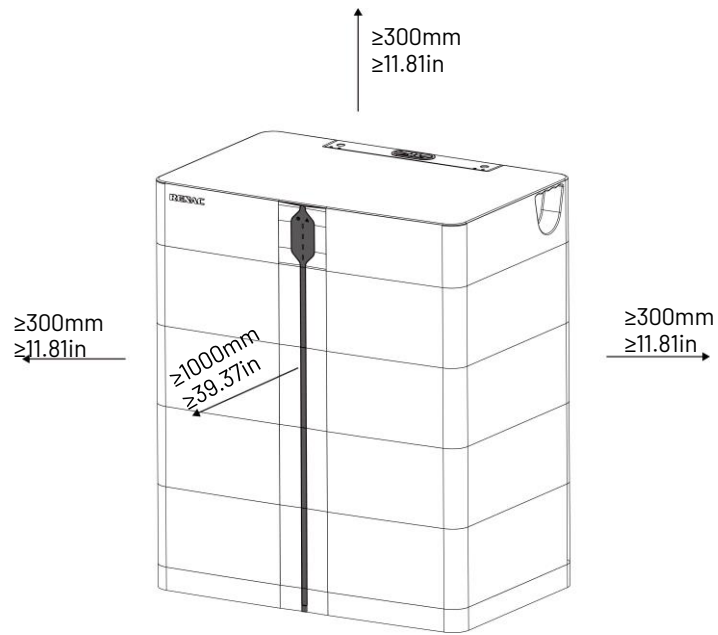

Figure 4-2 Installation space

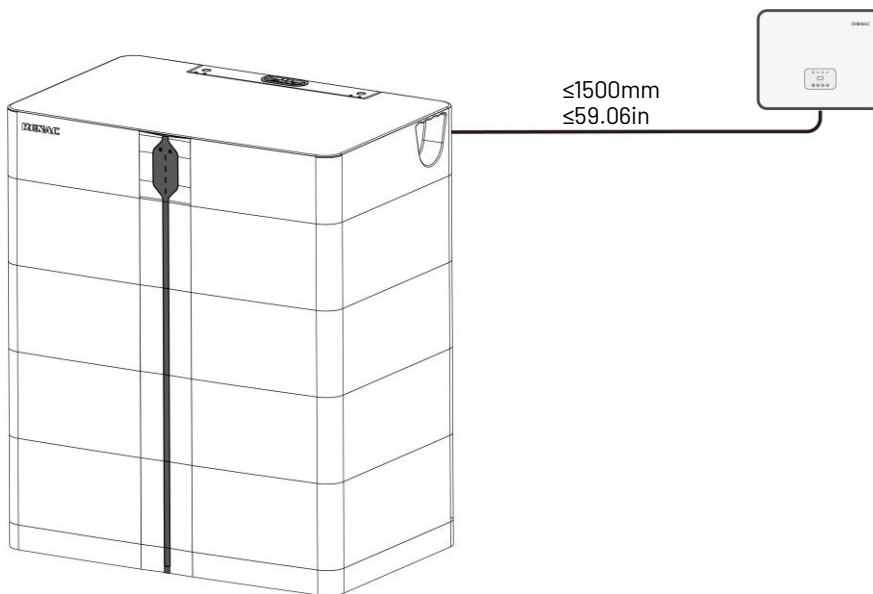

Figure 4-3 Recommended installation distance between Hybrid inverter and Turbo H4

4.5 Installation steps



Due to the heavy weight of the battery module, at least 2-3 people should work during manual handling and installation to avoid falling accidents or injuries.

1. Take the BMC and base out of the box, with the BMC700 underneath the base.

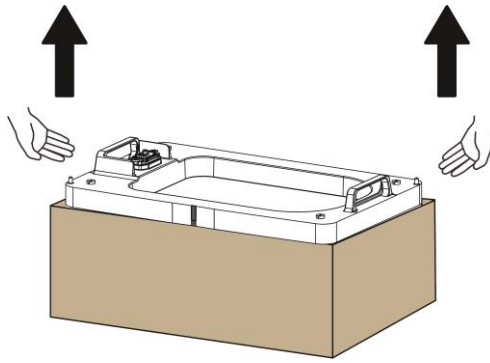

Figure 4-4

2. Place the base along the wall with a distance of 30-50 mm between the wall and the base, and use a spirit level to make sure that the base is parallel to the floor. The foot of the base can be fine-tuned by 5mm. Rotate it clockwise to lower the base; rotate it anti-clockwise to raise the base.

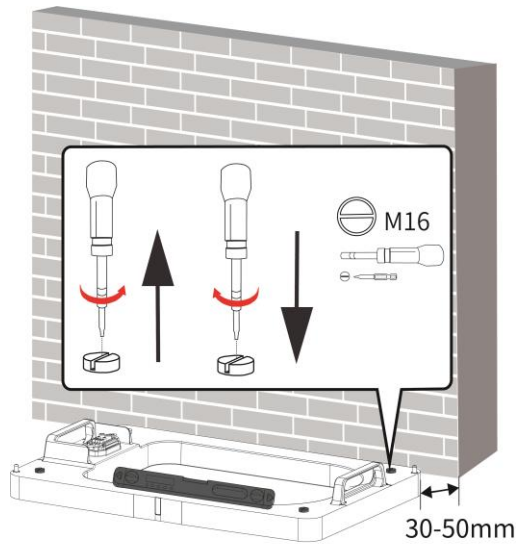

Figure 4-5

3. Remove the RBSs from the box.

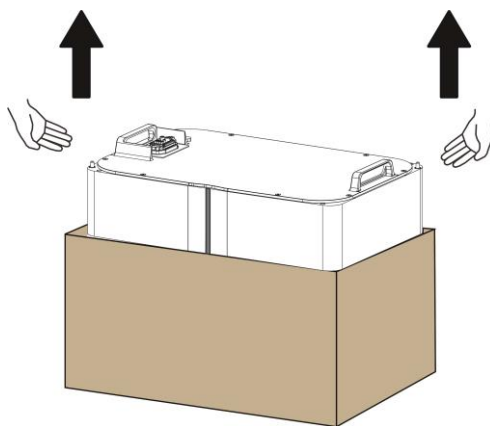
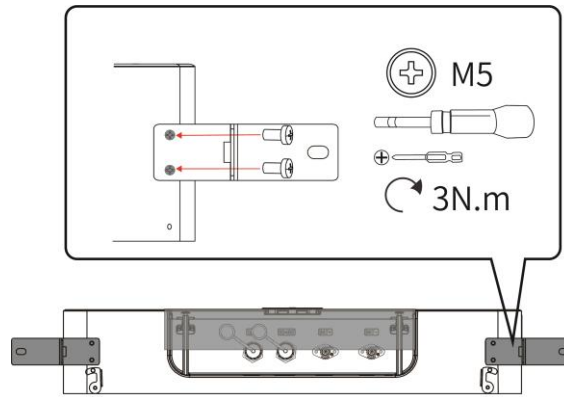

Figure 4-6

4. Pre-installed anti-tipping plate combination on the back of the BMC.



Back view of BMC

Figure 4-7

5. Stack the RBSs one by one on the base, and stack the BMC on top of the last battery pack.

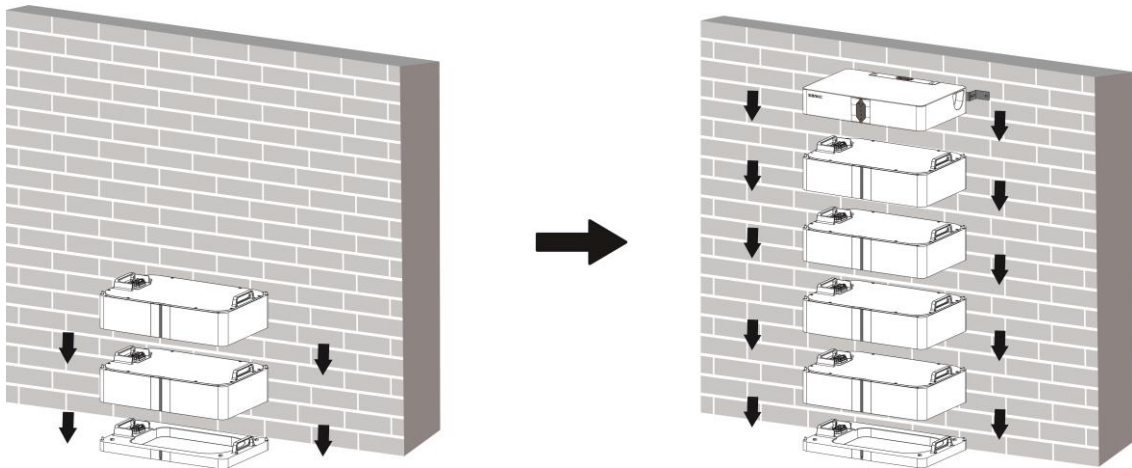
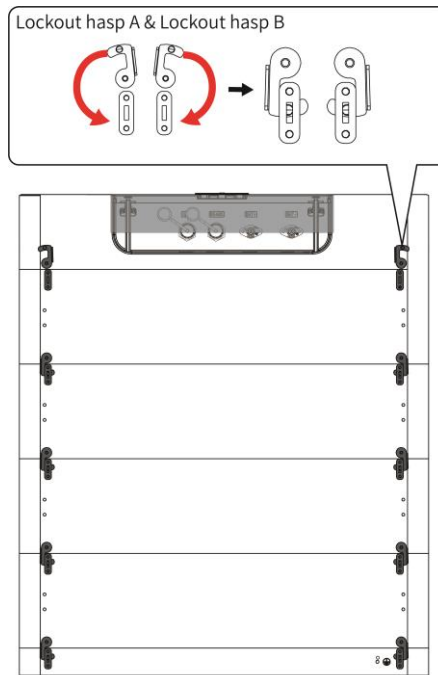

Figure 4-8

6. Rotate lockout hasp A and lockout hasp B half a turn to secure.



Back view of Turbo H4

Figure 4-9

7. Mark the holes with a marker pen according to the location of the anti-tipping plate, then rotate the anti-tipping plate assembly.

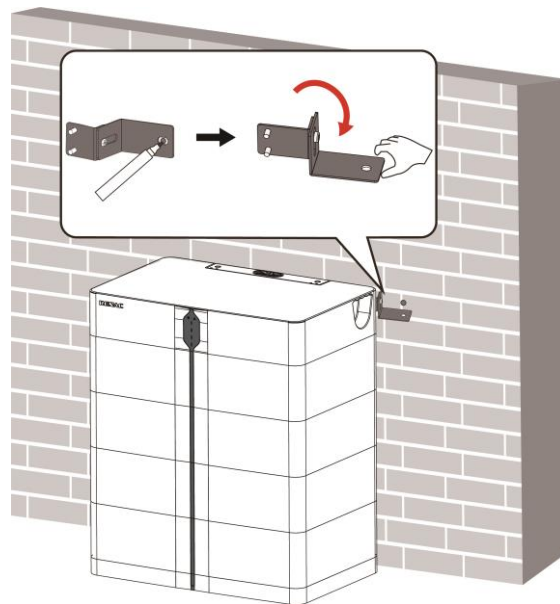

Figure 4-10

8. Drill $\phi 11\text{mm}$ holes to a depth of $\geq 50\text{mm}$ with a drilling machine.

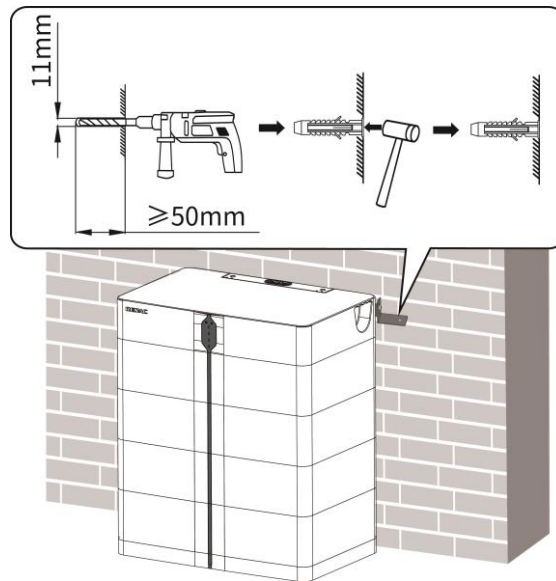

Figure 4-11

9. Insert the expansion tube, then fix the bracket B to the bracket A and screw the expansion screws.

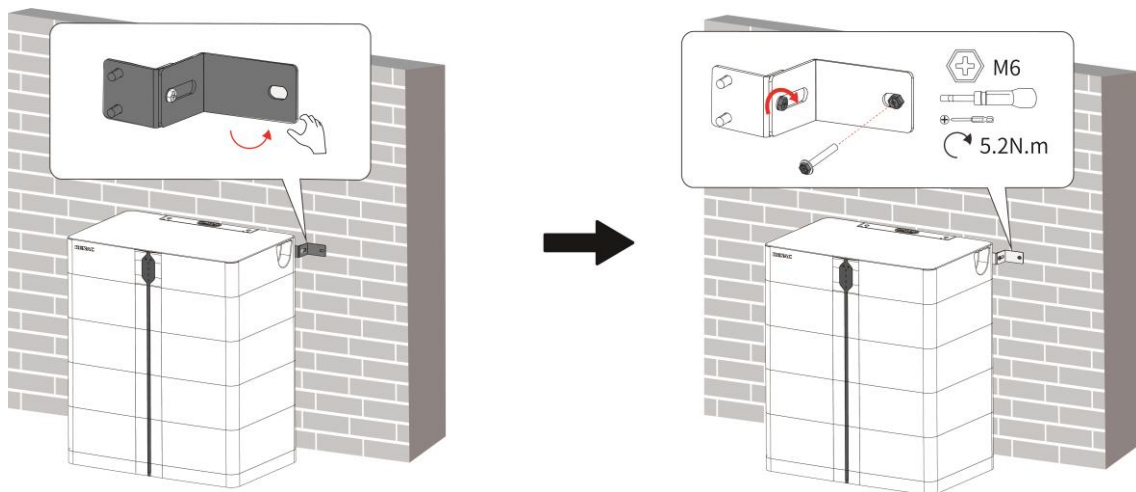

Figure 4-12

5. Electrical wiring connection



Before wiring, check that the battery system is installed correctly and ensure the DC switch of the BMC is OFF.

Overview of the cable connection:

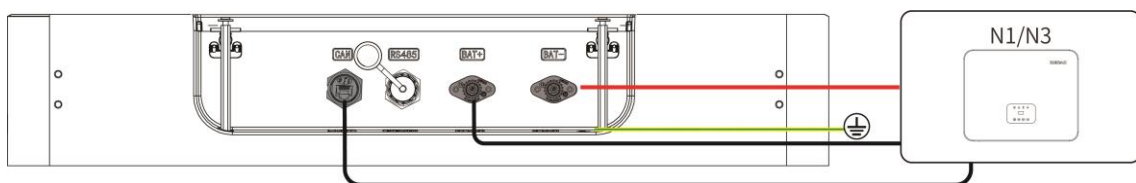

Figure 5-1

5.1 Port

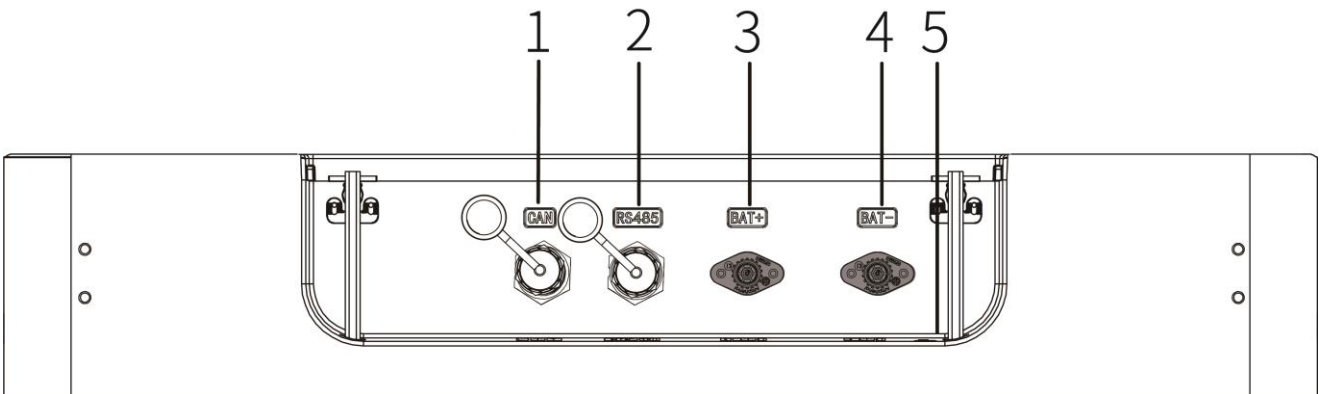

Figure 5-2 Ports of BMC

No.	Name
1	CAN: Connect the "CAN" port of BMC700 to the "BMS-CAN/485" port of inverter.
2	RS485: Debug port.
3	BAT+: Connect the "BAT+" port of BMC700 to the "BAT+" port of inverter.
4	BAT-: Connect the "BAT-" port of BMC700 to the "BAT-" port of inverter.
5	Grounding terminal: Connect to the earth.

5.2 Grounding cable preparation

1. Connect the grounding cable before connecting other cables. Users need to prepare their own grounding cable with a recommended cross-sectional area of 4mm².

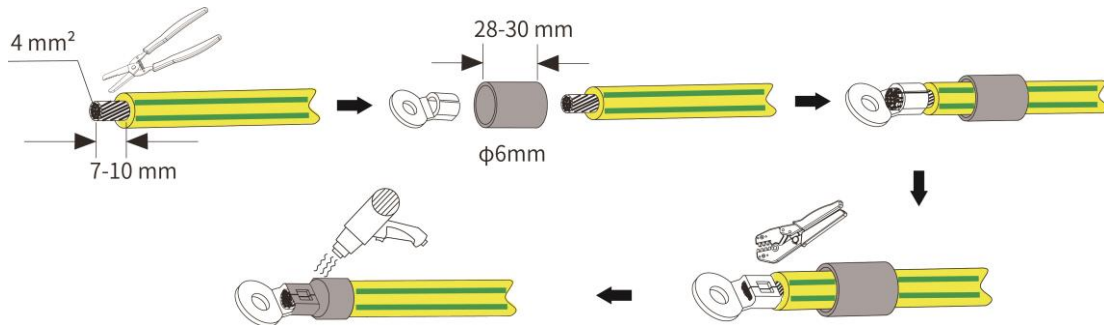

Figure 5-3

2. Open the cover and waterproof cover of the CAN communication port on the back of the BMC before you are ready to connect the other cables.

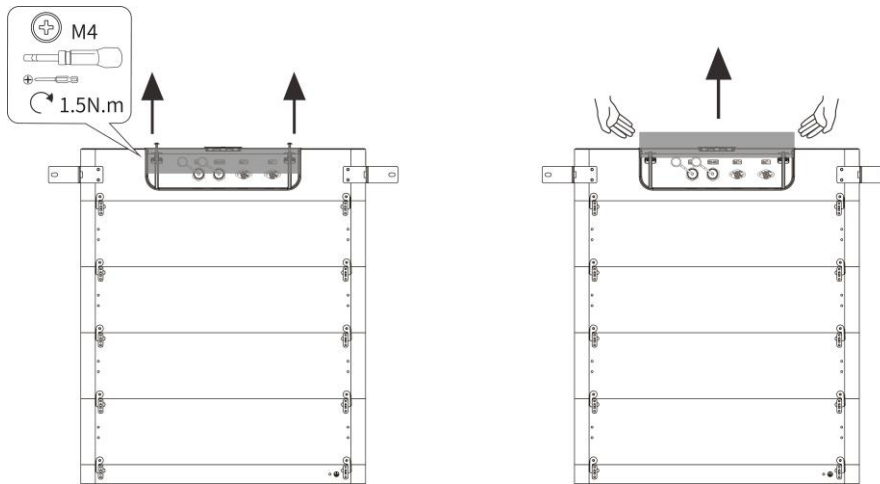

Figure 5-4

3. Connect the grounding cable to ensure that all batteries are grounded.

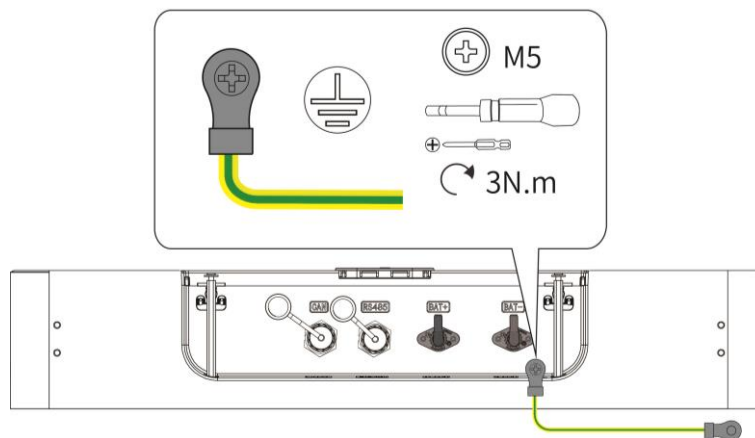

Figure 5-5

NOTICE

All cable connections go through the cable protection ring on the cover.

5.3 Battery power cable connection

Connect the red power cable to the red power terminal, and the black power cable to the black power terminal.

WARNING

Pay attention to the positive and negative terminals when connecting the power cables; the red wire corresponds to the positive terminal, and the black wire corresponds to the negative terminal; if it is connected backward, it may lead to battery damage.

Connect to N1-HV-3-6K:

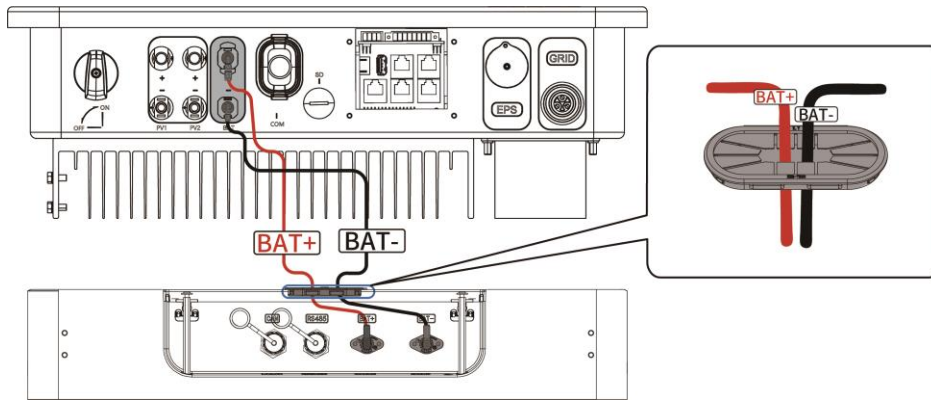

Figure 5-6

Connect to N3-HV-5-10K:

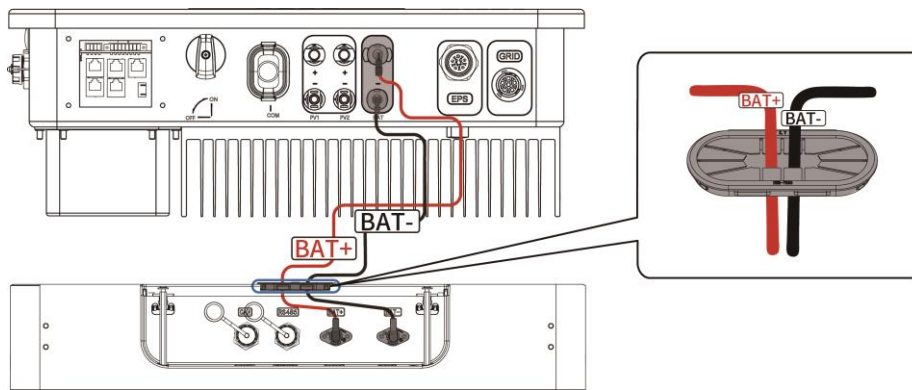

Figure 5-7

Connect to N3 Plus 15-30K:

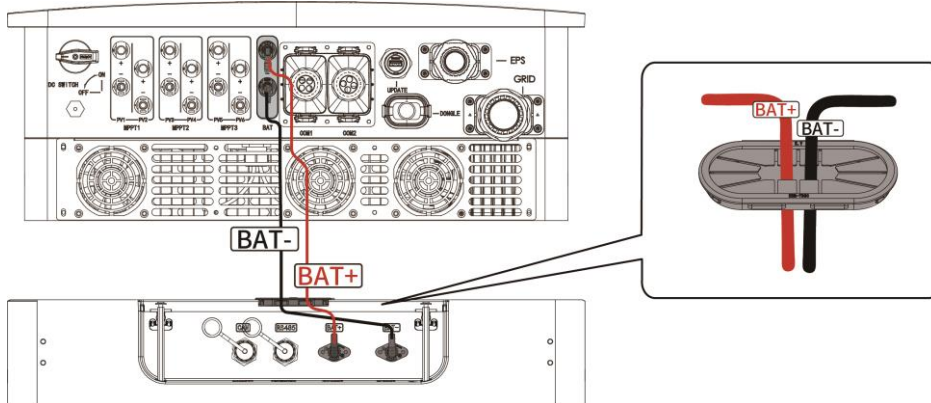

Figure 5-8

5.4 Communication cable connection

Connect the CAN port of the battery to the CAN port of the inverter.

Connect to N1-HV-3-6K:

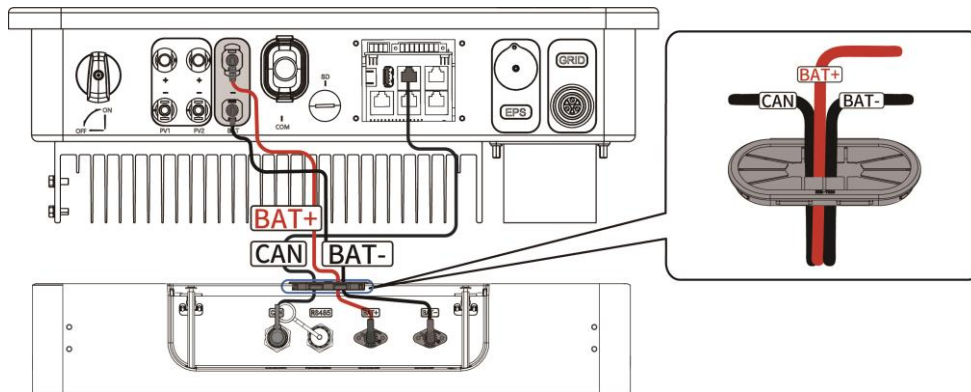

Figure 5-9

Connect to N3-HV-5-10K:

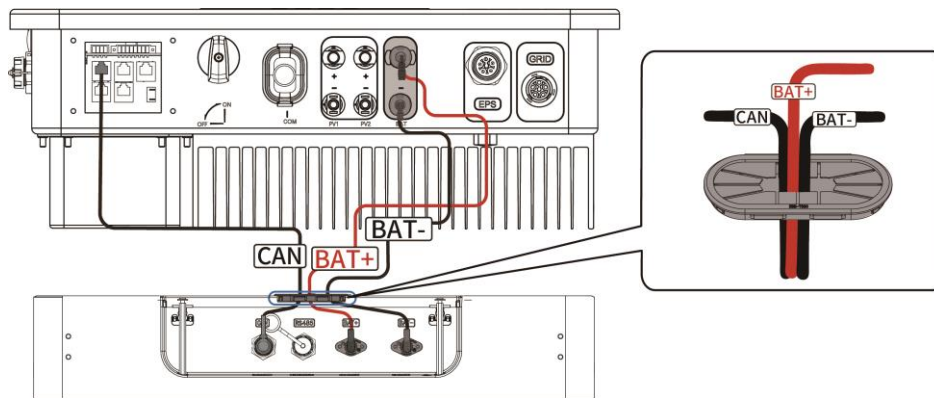

Figure 5-10

Connect to N3 Plus 15-30K:

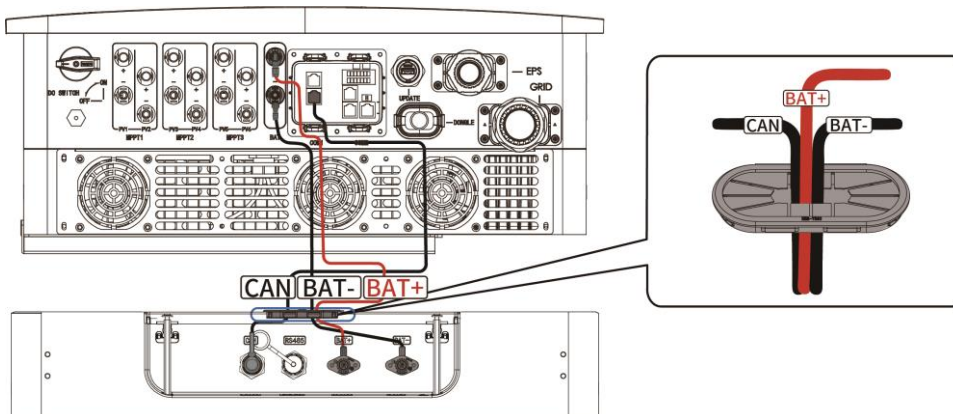

Figure 5-11

5.5 Close the cover

After electrical connections are complete, check all the cables are correctly and securely connected, and ensure that the battery can work normally before closing the cover.

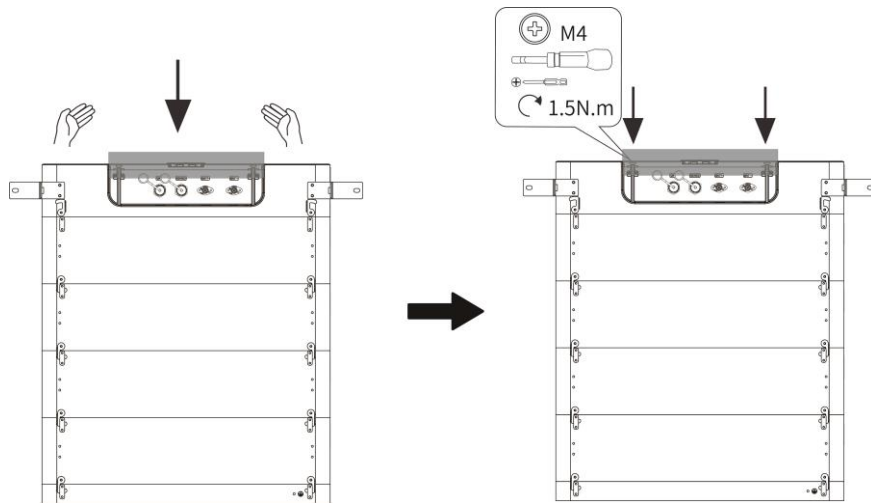

Figure 5-12

6. LED indicator status

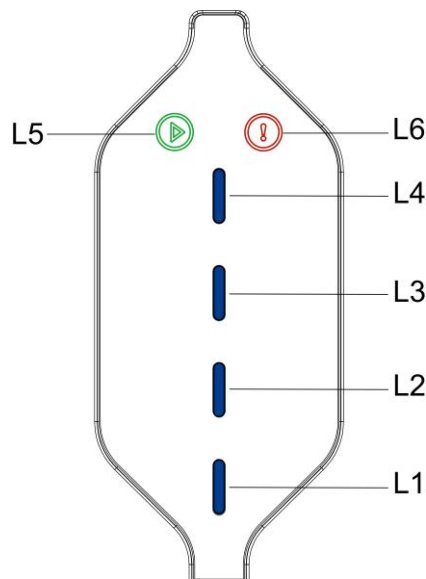

Figure 6-1

Status		Charging				Discharging			
		L4 ●	L3 ●	L2 ●	L1 ●	L4 ●	L3 ●	L2 ●	L1 ●
Battery SOC indicator		L4 ●	L3 ●	L2 ●	L1 ●	L4 ●	L3 ●	L2 ●	L1 ●
Battery SOC	0 ~ 25%	OFF	OFF	OFF	Flash	OFF	OFF	OFF	Light
	25 ~ 50%	OFF	OFF	Flash	Light	OFF	OFF	Light	Light
	50 ~ 75%	OFF	Flash	Light	Light	OFF	Light	Light	Light
	≥75%	Flash	Light	Light	Light	Light	Light	Light	Light

Status	Charging	Discharging
Normal status indicator	L5 ●	L5 ●
	Light	Flash
Abnormal status indicator	L6 ●	L6 ●
	Light	Light

7. Commissioning

7.1 Check before operation

Please check before operation:

RBSs, BMC, and base should be fully secured.

Grounding cables should be securely connected.

BAT+, BAT-, and CAN cables are firmly connected to the inverter.

The DC switch should be OFF, and all LEDs are off.

7.2. Power on

1. Switch on the DC switch.
2. Press the start switch to start system. After pressing the button, you can see that the LEDs begin to flash sequentially, and after stopping, the L5 running light is always on, which means that the power is successfully switched on.



If the battery does not turn on successfully, please check the fault code on the inverter. If it shows a PROTECT type of error, users can try to restart the battery; if it shows a FAULT type of error, please contact after-sales service and provide the type of fault to the after-sales service personnel; if the inverter doesn't show any information about the battery, it means the communication fault, please check whether the communication cable is connected correctly.

7.3. Power off

1. Press the start switch till you can see all the lights on the light board are off, indicating that the battery is switched off.



If users want to start the battery system again, wait at least 10min.

8. Troubleshooting and maintenance

8.1 Troubleshooting

If the red fault light is on, the battery is warned. Check the cause of the alarm on the LCD of the inverter or RENAC SEC.

The possible error information is shown as follows:

Fault	Cause	Solutions
Bat Volt Fault	Battery voltage fault.	Check if the battery input voltage is within the normal range, then restart the system and confirm whether the fault persists.
BatConDir Fault	The battery connection is reversed.	1. Check if the positive pole and negative pole of battery are correctly connected. 2. Contact the dealer or the after-sales service if the problem persists.
Bat Low Fault	Battery SOC is too Low.	1. Wait the battery to be recharged. 2. Disconnect the AC output switch and DC input switch, then connect them 5 minutes later. Contact the dealer or the after-sales service if the problem persists.
BMS Lost	The communication between BMS and inverter is interrupted.	Check if the communication cable between BMS and inverter is connected correctly.
BMS AD_AFE Fault	The difference between the total voltage of battery AD and AFE is too large.	1. Disconnect the AC output switch, DC input switch & battery switch, then connect them 5 minutes later. 2. Contact the dealer or the after-sales service if the problem persists.
BMS Tepr Fault	Battery temperature sensor fault.	
BMS InCom Fault	Battery internal communication fault.	
BMS Other Fault	Other battery fault.	
BMS PreChg Fault	Battery pre charge fault.	
BMS Relay Fault	The battery relay is fault.	
BMS Cell Fault	Battery cell error.	
BMS CMU Address	Cell monitor unit of battery self-networking is fault.	
BMS Protect OV	Battery over voltage protection.	
BMS Protect LV	Battery under voltage protection.	
BMS Prot ChgOC	Battery over current charging protection.	
BMS Prot DsgOC	Battery over current discharging protection.	
BMS Prot TemHigh	Battery temperature is high.	
BMS Prot TemLow	Battery temperature is low.	
BMS Volt Fault	Battery voltage sensor fault.	
BMS OutCom Fault	BMS external communication fault.	
BMS ISO Fault	Battery insulation test failed.	

Fault	Cause	Solutions
BMS Check Fault	Battery self-test failed.	1. Disconnect the AC output switch, DC input switch & battery switch, then connect them 5 minutes later. 2. Contact the dealer or the after-sales service if the problem persists.
BMS AFE Fault	Analog front end of battery is fault.	
BMS Prot TemDiff	The difference in battery cell temperature is too large.	
BMS Prot AD_AFE	The difference between the total voltage of battery AD and AFE is too large, triggering protection.	
BMS Prot Hard OC	Battery hardware overcurrent protection.	

8.2 Maintenance

DANGER

Use special protective gear and special insulating tools to avoid injury.
 Do not use water or any solvent to clean the battery.
 Wet rags are prohibited to be used to clean the exposed terminals or other parts that may conduct electricity.

WARNING

Maintaining the battery with electricity is prohibited, and you should wait at least 10 minutes after the battery is disconnected before performing maintenance.
 When performing maintenance on the battery, the exposed cable terminals need to be wrapped with insulating tape.

Batteries should not be stored in a low battery state as much as possible and need to be recharged in a timely manner; otherwise, they may be damaged by over-discharge.

Scenes that may trigger low battery storage:

- Battery power or signal wire not connected.
- Battery is not charging due to the system not being added or configured correctly.
- Battery cannot be charged due to prolonged power outages on the grid or no input on the PV side for an extended period of time.

WARNING

When the SOC of the battery is lower than 5%, it should be replenished in time within 7 days. Alternatively, the battery can be recharged with a 30A constant current for 15-20 minutes after being stored for six months. Otherwise, the battery damage caused by storing in a low battery state is not covered by the warranty.

9. Decommissioning

9.1 Dismantling the battery

1. Switch the battery off according to section 7.2 Switching off procedure.
2. Turn the DC switch to OFF.
3. Remove the communication, power, and grounding cables in turn.
4. Remove the bracket holding the battery in place.
5. Remove the control box and battery pack.

9.2 Packaging

If possible, please pack the battery with the original packaging. If it is no longer available, you can also use an equivalent carton that meets the following requirements.

- Suitable for loads more than 50kg.
- With handle.
- Can be fully closed.

9.3 Storage

Normal storage conditions:

1. When storing batteries, they should be placed correctly according to the box markings and not placed upside down or sideways.
2. Battery boxes should not be stacked more than 3 layers.
3. Batteries should be stored in a clean, dry and ventilated room.
4. Battery storage should avoid contact with corrosive substances and keep away from fire and heat sources.
- 5 Storage environment temperature and humidity requirements:

Recommended storage temperature: 15°C ~ 30°C, permissible environmental range: -10°C ~ 53°C;

Recommended relative humidity: 5 ~ 80%RH.

Over-term storage conditions:

Generally we do not recommend long-term storage of the battery, but if you really need to store it for a long time, please replenish the electricity according to the following requirements.

Temperature range	Actual storage temperature	Charge cycle
-10°C < T ≤ 53°C	T ≤ -10°C	Impermissible
	-10°C < T ≤ 0°C	6 months
	0°C < T ≤ 35°C	4 months
	35°C < T ≤ 53°C	3 months
	53°C < T	Impermissible

9.4 Disposal

Disposal of the system must comply with the local applicable disposal regulations for electronic waste and used batteries.

- Do not dispose of the battery system with your household waste.
- Avoid exposing the batteries to high temperatures or direct sunlight.
- Avoid exposing the batteries to high humidity or corrosive atmospheres.
- For more information, please contact RENAC.



User Manual Download URL



www.renacpower.com

422-00296-00

SMART ENERGY FOR BETTER LIFE

RENAC

RENAC POWER TECHNOLOGY CO., LTD.

☎ +86-0512-66677278

✉ info@renacpower.com

🌐 www.renacpower.com

🏠 Block C-12, No. 20 Datong Road, Comprehensive Bonded Zone,
Suzhou Hi-Tech District, Suzhou, China